

SIA1/SIA3/XP2 MOTION

INSTRUCTION MANUAL FOR THE
WIRELESS MOTION CONTROL SYSTEMS ERIES

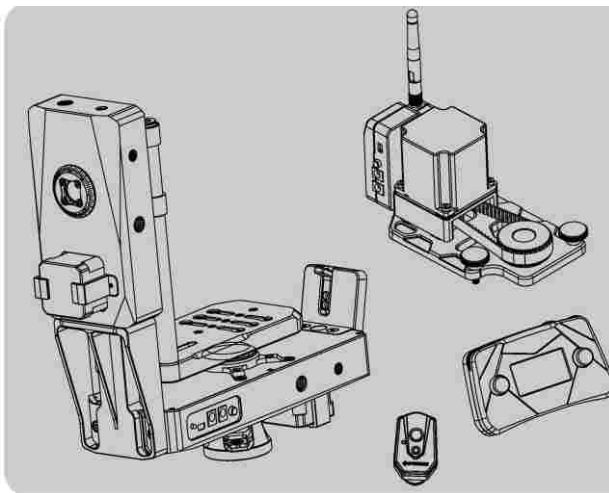

 **IFOTAGE**

DK0328001

Thank you for purchasing this iFootage product. The multi-axis motor control system has a compact and sleek design and features wireless motion control for time-lapses, special-effect, panorama shots and matrix-shot applications.

This instruction manual applies to the Wireless Motor Control System S1A1, Motion X2, and S1A3. However, because each model has a different application, please refer to the instruction content of the model you purchased.

To get the most of your motor control system, please read the instructions fully before operating the equipment and keep the manual safe for future reference.



Caution:

1. Whilst every care has been taken to anticipate the needs of the customer and to make this manual correct and complete, some ambiguity or description omissions may exist. We welcome customer feedback on how we can improve the product manual.
2. Before the first use, please read the "Safety guide" section (P14-P15).
3. Please check all components and packaging for any damage. In the case of defective parts or shortage, please contact your distributor as soon as possible.
4. The camera, pan head, jib, and tripod in this instruction manual are for reference only and are not included in the wireless motion control system package purchase.

Technical Information

S1A1

Speed range	0mm/s-160mm/s	Endurance time	25% Power 9-26H
Accuracy	0.00325mm	Endurance time	50% Power 6-16H
Max. vertical load	8KG/17.6P	Endurance time	100% Power 4-10H
Motor power	8-32W	Operating voltage	DC14.8-24V
Speed regulation	Stepless speed / step speed	Radio Signal Range	20m
Radio frequency	2.4GHz	Self weight	1.1KG/2.4P



Endurance time	10 ~ 16H	Best load	4KG/8.8P
Spin speed	0-40°/s	Maximum load	8KG/17.6P
Accuracy	0.0025°	Operating voltage	DC14.8-24V
Motor power	8-32W	Radio Signal Range	20m
Speed regulation	Stepless speed / step speed	Weight	2.5KG/5.5P
Radio frequency	2.4GHz		







Wireless Controller

Radio frequency	2.4GHz	Endurance time	50h
Operating voltage	3.7V	Weight	0.42KG/0.9P
Built-in rechargeable lithium battery		Radio signal range	20m

Shutter section

Radio frequency	2.4GHz	Endurance time	50h
Operating voltage	3V	Weight	0.04KG/0.1P
2 *AAA batteries (LR6)		Radio signal range	20m

Model and shutter cable compatibility

<p>DC0</p> 	<p>Nikon</p> <p>Fujifilm</p> <p>Kodak</p>	<p>D800, D810, D810A, D800E, D700, D1series, D2series, D300 series, D200, D3X, D4, D4s, N90s, F5, F6, F100, F90, F90X</p> <p>S5 Pro, S3 Pro</p> <p>DCS-14n</p>
<p>DC2</p> 	<p>Nikon</p>	<p>DSLR D7000, D7100, D7200DF, D5500, D5300, D5200, D5100, D3300, D3200, D3100, D750, D610, D600, D90</p>
<p>N3</p> 	<p>Canon</p>	<p>EOS 7D, 6D, 5Dseries, 1Dseries, 50D, 40D, 30D, 20D, 10D, 5DSR</p>
<p>E3</p> 	<p>Canon</p> <p>Pentax</p> <p>Samsung</p> <p>Contax</p>	<p>PowerShot G10, G11, G12, G1X, 700D, 70D, 100D</p> <p>EOS 1100D, 1000D, 650D, 600D, 550D, 500D, 450D, 400D, 350D, 300D, 60Dseries, 30, 33, 50, 300, 750D, 760D</p> <p>K-5, K-7, K10, K20, K100, K200</p> <p>GX-1L, GX-1S, GX-10, GX-20, Nx100, Nx11, Nx10, Nx5</p> <p>645, N1, NX, N Digital.al</p>
<p>S1</p> 	<p>Sony</p> <p>Konica</p> <p>Minolta</p>	<p>DSLR a900, a850, a700, a560, a550, a500, a450, a400, a350, a300, a200, a100, a99, a77, a77II, a65, a57, a55, a35, a33</p> <p>DIMAGE a2, 1, 9, 7Hi, 7i, 7, 5, 4, 3</p> <p>DYNAX 7D, 5D</p>
<p>S2</p> 	<p>Sony</p>	<p>A58, NEX-3NL, A7/A7R, A3000, A6000, HX300, HX50, RX100M2, HX400, HX60, A7S, A7II, A7RII, RX10, RX10II, RX100III, RX100III, RX100IV</p>
<p>L1</p> 	<p>Panasonic</p> <p>Leica</p>	<p>DMC-FZ50, DMC-FZ50K, DMC-FZ50S, DMC-FZ30, DMC-FZ150, DMC-FZ30K, DMC-FZ30S, DMC-FZ20, DMC-FZ20K, DMC-FZ20S, LC-1, L1, L10, G10, G2, G1, Gf1, Gh1, Gh2, G3, Gx1, Gh4</p> <p>DIGILUX2, DIGILUX3</p>

Features

1. 2.4GHz wireless control free from the limitation of wires.
2. Ergonomic operation design.
3. Digital control and high precision location - the highest location accuracy for motor section is 0.00325mm, and for the Pan & Tilt Head it is 0.0025°.
4. Automatic original point detection which eliminates the need to manually reset for multiple shootings.
5. Functions include time-lapse, special-effect, panorama shot, track playback, video-shot, live-mode, and matrix-shot application.
6. With the use of modular design, each module can communicate with each wireless motor individually.
7. The drive mode of the FOC vector shine-wave facilitates the quiet, accurate, of high precision and free of vibration use.
8. One key update system firmware. Users can download the updated firmware from www.ifoatagegear.com.
9. The compact design allows pieces to fit nicely into carrying case. Each piece is modular and can be used independently.
10. Multi-level driving gears which offer high-precision. More important, they facilitate the biggest torque power without users having to replace different gears; speed variation is 0-160mm/s for slider, 0-40°(Pan & Tilt Head).
11. Precise CNC machined cutting technology which strengthens the toughness of metal, while the black anodised finish increases product durability.

Wireless Controller

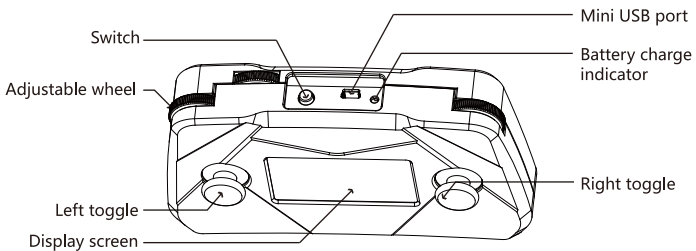

Mini USB port: to update firmware or charge the battery

Left/Right toggle: press the toggle to confirm operation for certain interface

Motor Section

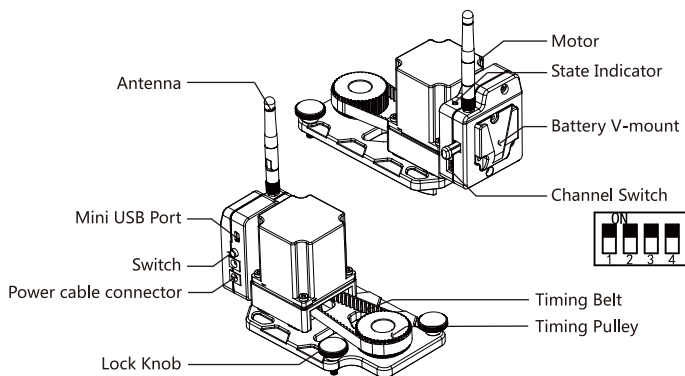

Wireless Shutter Controller

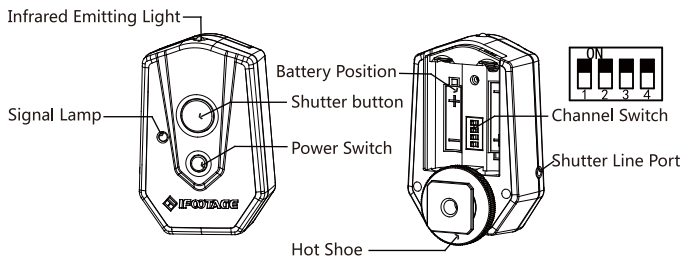

Battery position: Two AAA batteries(LR6)

Pan & Tilt Head

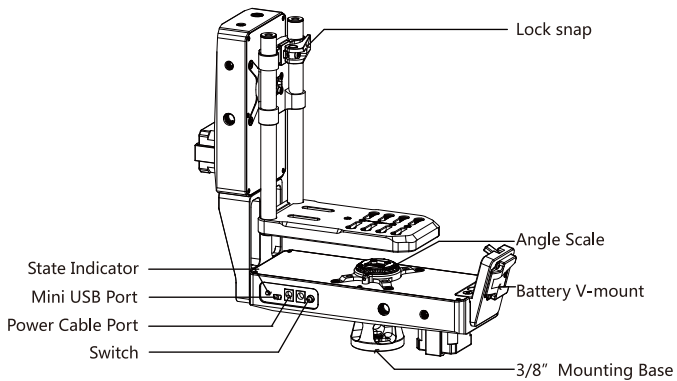
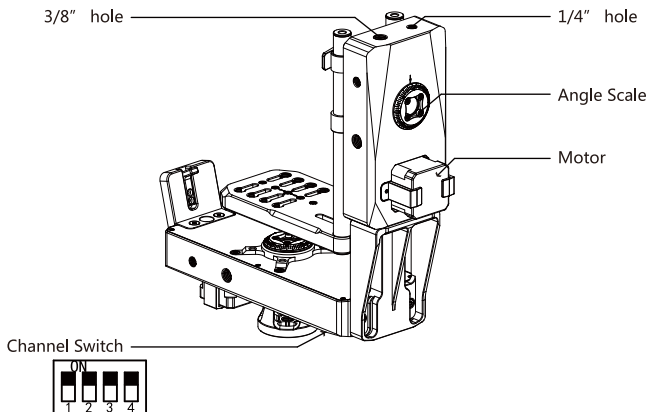

Before Installation

Before using the iFootage S1A1/S1A3/MOTION X2 system for the first time, you must ensure that the frequency channel of every section is set consistent (for the wireless motorised controller, users should check the channel status in SET menu or press and hold the left toggle to set the channel). The firmware version of every section should also be the same so that the whole system can be controlled by one wireless motorised controller, which then creates synchronous movement.

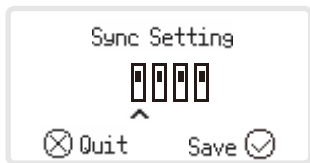

Channel setting for wireless motorized controller

Channel setting for wireless shutter controller

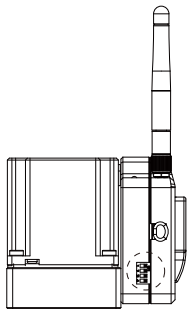
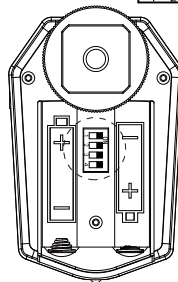

Channel setting of motor section



Channel setting of pan & tilt head

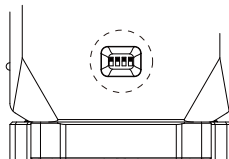

Before Setup

The Wireless Controller can control one or multiple motor sections

a. Wireless Motorized Controller controls single motor section

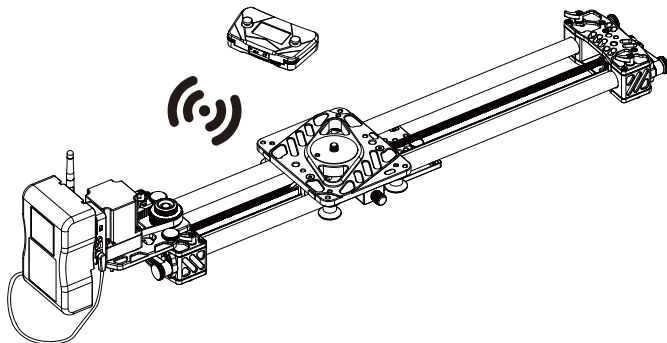

b. Wireless Motorized Controller dominates multiple motor sections at the same time

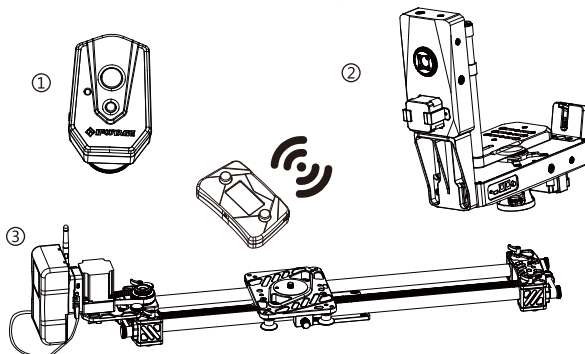

Before Setup

After it has been switched on, Motion X2 automatically looks for the initial status/zero point.

Please ensure there is no obstacle around the equipment before starting up.

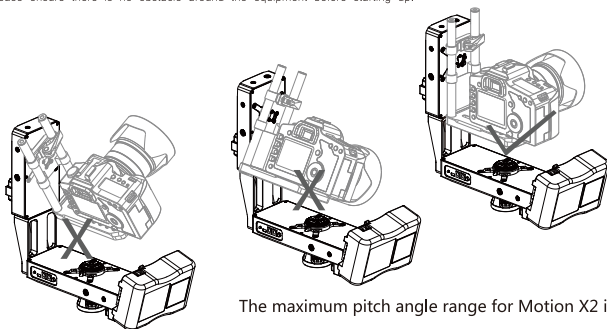

The maximum pitch angle range for Motion X2 is $\pm 30^\circ$

Application Scene

01

Install S1A1

a.

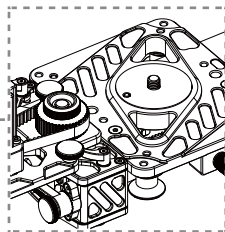
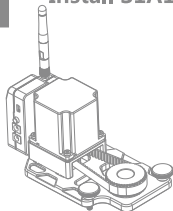

b.

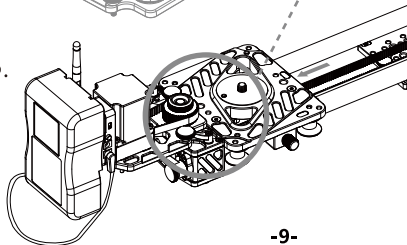

After finishing the installation and before starting up, please move the main body to the nearest location (1-2cm away from motor section)

Setting up the equipment

02

Mount the Motion X2 onto the tripod

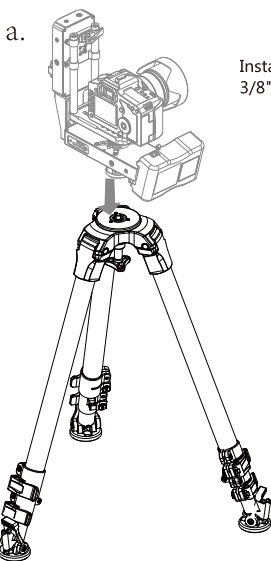

Install the hemisphere base on the tripod in the 3/8" hole at the bottom of Motion X2

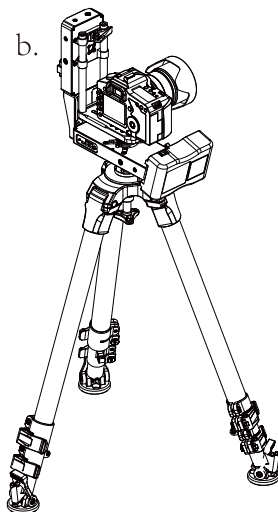

Setting up the equipment

03

Combine Motion X2 with S1A1 into S1A3

Step1: Install the Mounting Base onto slider and tighten the four screws

a.

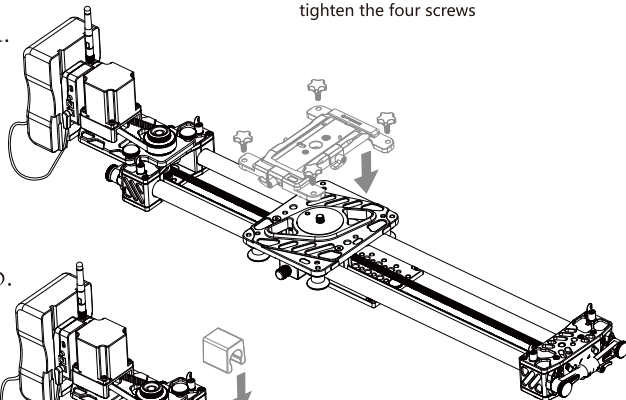

b.

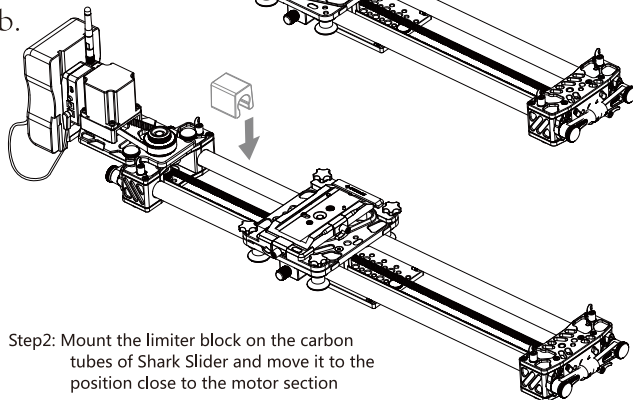

Step2: Mount the limiter block on the carbon tubes of Shark Slider and move it to the position close to the motor section

Setting up the equipment

Step3: Mount the quick release plate onto the bottom of the Pan & tilt head, then use the mounting base to connect S1A1 to Motion X2

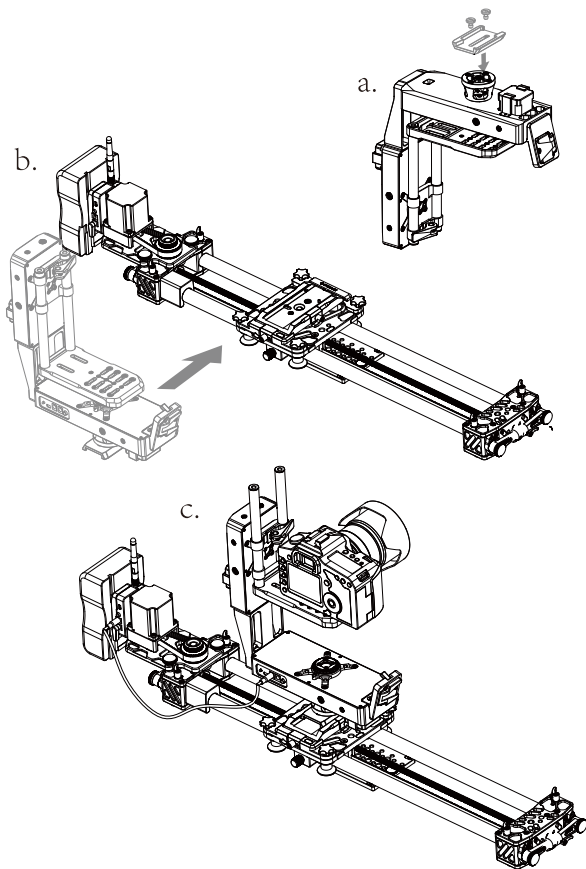

Setting up the equipment

04

Connect Motion X2 with jib

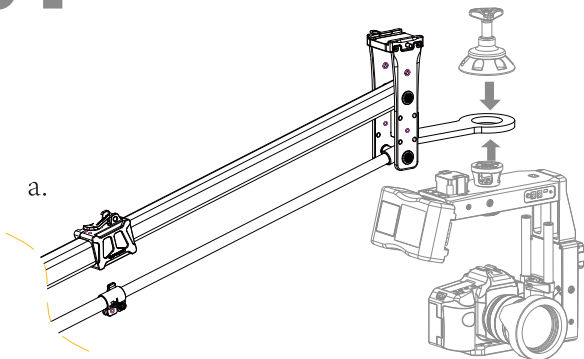

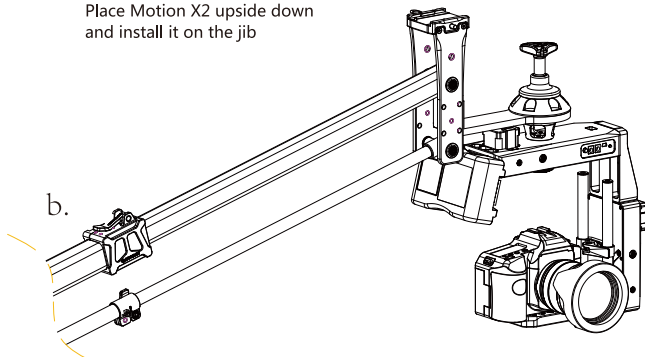

Place Motion X2 upside down
and install it on the jib



* After mounting Motion X2 to jib, reverse the operation
direction of Pan & Tilt Head in the system setting.

Safety and precaution

1. Please apply the pre-recorded track when operating the time-lapse or automatic shooting function. Otherwise it will not run.
2. Adjust all channels in sync when using one wireless controller to control multiple sections. The wireless controller also separately works for the motor section/shutter section/Motion X2. To save power, turn off the controller when running the set-up track.
3. Slide the left toggle from side to side to control the running direction and speed, or press and hold the left toggle into the channel setting. Sliding the left toggle in the controller interface can move the cursor left, right, up and down. Go back to the previous interface by pressing the left toggle.
4. Slide the right toggle from side to side to control the running direction and speed of the pan axis or pitch axis. Under the main interface of the wireless controller, slide the left toggle up and down or left and right to change the data. Press and hold the right toggle to enter the current interface and operate the current operation.
5. Adjustable wheel can toggle between the fixed speed to infinite variable speed in manual menu. Slide adjustable wheel clockwise and display  indicating it's in fixed speed mode. In this case the left toggle only can control direction instead of speed. Continuously slide adjustable wheel until display  means it's in toggle-control speed mode.
6. It is recommended to use the original battery in 14.8V with B output and V mount port. Alternatively 14.8V-24V(3A above) DC power supplies are also suitable. Ensure the battery is fully charged before use. Charge it on time when it is in low volume, as sudden power loss during use may cause damage to the system and the camera.
7. When the wireless motorised controller is on low battery, please charge it in good time by using the mini USB cable or the iFootage USB connection. During charge, the charge indicator flickers constantly. The charge value should be within 0.5A and 1.2A. The battery must be changed if it is not used for over a year.
8. The working light on the electronic motor section flashes green regularly(every 2 seconds) to indicate the system is working properly. If the voltage is lower than 14V, it flashes red once every 0.2 seconds. It turns red without flash when the voltage is lower than 12V (you must charge the battery in time) or higher than 26V, so please ensure the equipment is operated at a normal voltage.
9. When switching off Motion X2, the wireless controller will display: Pan & Tilt Head is back to the starting point? Before pressing the OK button, please make sure the base plate of the camera is within a $\pm 30^\circ$ range.
10. It is recommended to set the 25% power consumption when placing the product horizontally, as this can greatly extend the battery life. Set the appropriate power consumption according to the advised load capacity.
11. Before switch off, make sure the main body of the Shark Slider has been moved close to the motor section. Do not put your hand near any side of the slider or the timing belt to avoid finger clipping.

Safety guide

12. Pay attention to the rotation direction of the Pan & Tilt Head to prevent collision and damage of the camera.
13. Don't change the launch frequency without supervision. DO NOT connect other antennas or change to other types of antennas.
14. Keep the equipment away from rain or humidity to avoid the risk of fire or electric shock. Do not use it without protection in a dusty environment or rainy weather as this may cause equipment failure.
15. Any arbitrary disassembly, modification without authorisation, physical impact and rough use of the equipment are not recommended.

Manual Menu

Operate the toggle or adjustable wheel to control the real-time position, speed, angle etc. of the Shark Slider's main body and Pan & Tilt Head.



Main Interface
of Manual

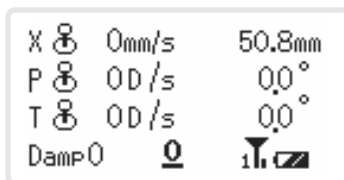

X : Horizontal direction of slider D/s : Degree/Second (speed of Pan & Tilt Head)

P : Pan, horizontal angle of Pan & Tilt head : Power : Adjustable speed

T : Tilt, pitch angle of Pan & Tilt head : Toggle control speed

Damp : Adjustable level 0-3 mm/s : Millimetre/ second (speed of slider)

mm : Millimetre (slider position) : Signal 0.0° : Angle position of Pan & Tilt head

: return to original point (into manual interface, press down right toggle)

1. Slide the left toggle from side to side to control the running direction of the slider, and adjust the toggle angle to control the slider speed.

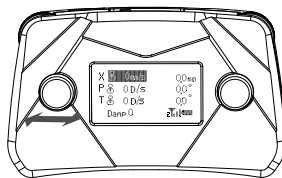

2. Slide the right toggle from side to side to control the pan axis, and adjust the toggle angle to control the speed of the pan axis within a 0-40°/s range.

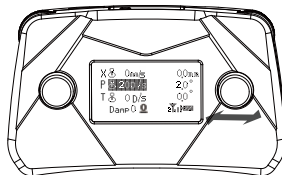

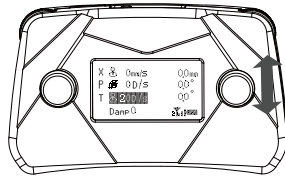

3. Slide the right toggle up and down to control the tilt axis. Adjust toggle angle to control the speed of the tilt axis within a 0-40°/s range.

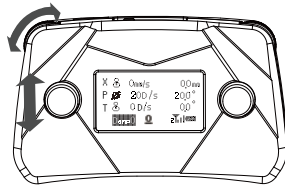

4. Slide the left toggle up and down to move the cursor. Its speed is also controlled by the left toggle.



5. Sliding left adjustable wheel will shift between toggle-control speed and wheel-control speed. Slide clockwise and interface displays , indicates if it is in wheel-control mode. Continuously slide wheel changes the speed value: 0-160mm/s for Slider, 0-40°/s for Head. Slide anti-clockwise and interface displays , indicates it is in toggle-control mode. Slide left toggle up and down to move cursor to Damp. Slider wheel to change Damp value within range of LV0 --LV3. The bigger the number the higher the Damp value.

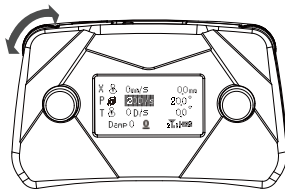

Record Menu

A time lapse or automatic shot needs to apply the pre-recorded track, which makes the Record Menu a very important function.



Main interface
of Record

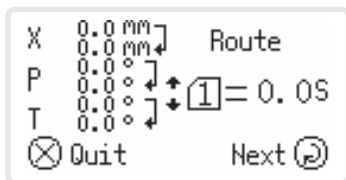

:Current position of Pan & Tilt head and slider

0.0S

: Displays the time of the pre-recorded track. It displays 0 for an unrecorded track

Next



: Select track package number and press Next in the **Start set-up Interface**. It is operated the same way as the Auto Menu

1: Select related track package. A total of 9 track records can be saved. The newly created record is saved over the old one if the user chooses the same track package number

Start Set-up Interface

Rec : Press the recording icon. After adjusting the location of the slider or the Pan & Tilt Head, the speed, and damp, press Record and start recording

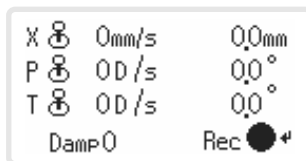





* On this interface, press Record to start recording. This will make the slider and the Pan & Tilt Head move while the system automatically records the speed, direction, time, angle and the distance of the move. Press the right toggle to finish recording the track.

Real-time Record interface

2. 2 S :Recording time (maximum recording time is 60 seconds)

Stop : Stop record icon. Press the right toggle to finish recording

X 	0mm/s	0.0mm
P 	0D/s	0.0°
T 	0D/s	0.0°
DAMP0	2. 2S	Stop 

Auto Menu

Based on the pre-recorded track or automatic track, you can achieve A to B, A to B to A movement. After the track setting, the slider will operate according to the variable speed, direction, distance in the pre-recorded track.



Main interface
of Auto

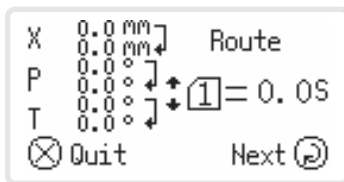

0.0S : This is the total time of the track package

↕1 : Select pre-recorded track package

Next ⌂ : Press Next to go to **Mode Interface**

Mode Interface

A-B mode : Shoot from starting point A to end point B at a constant speed

A-B-A mode Automatically shoot a cycle from starting point A to end point B, and then finally back to A at a constant speed

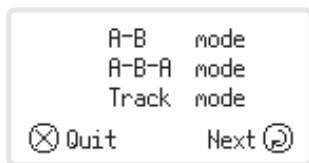

Track mode : The slider operates according to the pre-recorded track. Its direction and speed change automatically depending on the total run-time

Next ⌂ : select related mode and enter the **Time Setting interface**

* A-B mode and Track mode are suitable for vector video shooting which combines several same-track shoots into one.

* A-B-A mode is suitable for studio work or talk shows.

Time Setting interface

Run time : Set up total time of automatic running

Fade in : set up ease-in time (time to start damp)

Fade out : Set up ease-out time (time to stop damp)

Next  : Press Next to enter the **Running Mode interface**

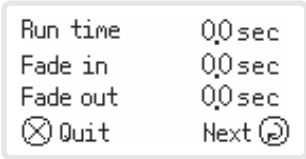

```
Run time      00sec
Fade in       00sec
Fade out      00sec
⊗ Quit       Next 
```

* The longer the time in the running setting, the lower the speed of the equipment is. In contrast, the shorter the time in the running setting, the faster the speed of the equipment is.

Running Mode interface

Single run :Single running

Circle run :Constant cycle running

Quick back :Equipment runs back to the starting point

Next  : Press Next into Real-time Run interface and the equipment goes back to the starting point at the same time

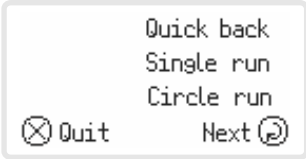

```
Quick back
Single run
Circle run
⊗ Quit       Next 
```

* To select Single Run only operate one running, and equipment stop at the end point. To select Cycle Run activates circle running repeating the current track.

Real-time Running interface



going back :Running back to the start point

0000:00:00 :Real time of current running

0.0% :The percentage of current running

Stop  :Stop current running and return to previous interface



```
X 0mm | going back
P 0°  | 0000:00:00
T 0°  | 0.0%
Stop  |  
```

Panorama & Matrix Menu

Before operating this function, please set up the single frame angle. You can then get the panoramic stitching or matrix stitching effect by operating the camera on the Pan & Tilt Head to shoot multiple pictures from different angles.



Main interface of
Panorama & Matrix

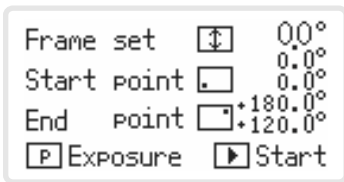

Frame set :Set up the top edge and the bottom edge of the wide-angle viewfinder

Start point :Move lens to the bottom left and set up the start point

End point :Move lens to the top right and set up the end point

[P] Exposure :Set up exposure time and exposure waiting time

[▶] Start :Start matrix shoot (set up the camera frame, start point, end point, shooting parameters, and then press Start to shoot)

Interface of Picture setting

Select Auto set according to the focal length and press Next to enter the **interface of Auto set according to the focal length**

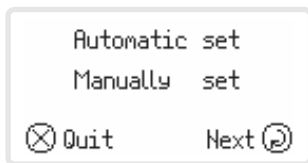

Select Manual set according to the frame and press Next to enter the **interface of Manual set according to the frame**



Interface of Auto set according to the focal length

Camera frame : Full, Aps-C, M4/3, three options

Focal length : Set up lens focal length

Frame angle : System automatically calculates the angle by camera frame and lens focal length

Save  : Saving current position

Camera frame Full
Focal length 50 mm
Frame angle = 26.9 °
 Quit Save 

Interface of manual set according to the frame



The camera lens moves to the bottom of the frame

In this instance, the purpose of the single frame setting is to enable the system to automatically calculate the quantity of photos the panorama shoot needs, and then sets the bottom of the frame









The camera lens moves to the top of the frame



In this instance, the single frame setting enables the system to automatically calculate the quantity of photos the panorama shoot needs, and then sets the top of the frame

 **Quit**: Exit current operation and don't save

Save  : Save current frame set and return to main interface of Panorama shoot

P 00/s 0° 
T 00/s 0°
Select a target,
 Quit Next 

P 00/s 0° 
T 00/s 0°
move the head and make
 Quit Next 

Frame angle = 00°
Save ?
 Quit Save 

Interface of Start point setting

: Means moving the lens to the bottom left corner. Move the lens to the bottom left corner, press Save, and the system saves the current position as the start point

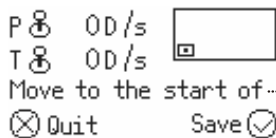

Interface of End point setting

Quick set: Set up end point by inputting angle value

Manually set: Set the end point by rotating the angle of the Pan & Tilt Head

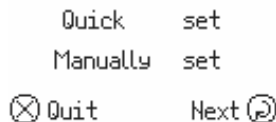

Interface of Quick setting

: Add angle value based on the start point, and set it as end point

Pan: Horizontal rotation angle of the Pan head in the 0-360° range

Tilt: Pitch rotation angle of the Tilt Head in the 0-360° range

Save : Press Save

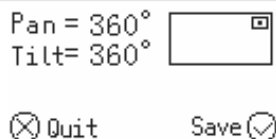

Interface of Manual Setting

: Means moving the lens to the top right corner. Move the lens to the top right corner, press Save, and the system saves the current position as the end point

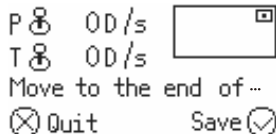

Interface of Exposure

Exposure :Set up the camera exposure time. When the time setting is 0, the exposure time is automatically controlled by the camera. When the time setting is >1, the exposure time is controlled by the wireless shutter section

Hold time :Allow enough time for the camera save the data before moving the Pan & Tilt Head

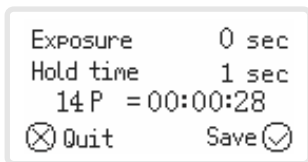

* Typically if the exposure time is 0, it is best to set the auto camera exposure. Setting up a specific exposure time is only needed if the camera is in Bulb mode. After completing the setting, save and return to the Panorama shooting interface.

Press  **Start** to enter **real-time interface of Panorama shooting**

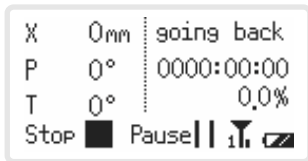

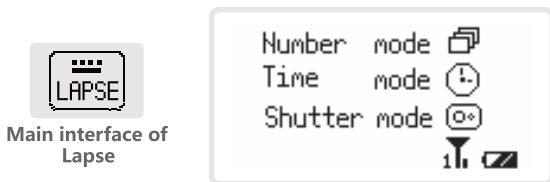

Lapse Menu

Lapse shooting includes three modes. The Number mode and the Time mode are applicable to single-axis or multi-axis motion shooting (the setting is the same for both). Shutter mode is suitable for timelapse shooting with the wireless shutter trigger.



Number mode : Customised setting based on the quantity set up by the user

Time mode : Customised setting based on the total time set up by the user

Shutter mode : Shutter mode is suitable for timelapse shooting with the wireless shutter trigger

Interface of Number mode

 = 0.0S : Pick the existing pre-recorded route

Next  : Enter setting menu of number mode

The screenshot shows the Number mode interface with the following text: "X 0.0 mm", "P 0.0 mm", "T 0.0 mm", and "0.0 mm". To the right of these values are arrows pointing up and down. Further right is the word "Route". Below the "T" value is a square icon followed by "= 0.0S". At the bottom left is a circle with an "X" and the word "Quit". At the bottom right is the word "Next" followed by a square icon.

Interface of number mode

Quantity 20 P : Set the total quantity of photos you want to shoot

Exposure 0sec : Input values only when camera is in Blub mode. Other modes defaults as 0

The screenshot shows the number mode settings interface with the following text: "Quantity 20 P", "Exposure 0sec", "Interval 2sec", and "Total 0000:00:40" with a downward arrow.

Interval 2sec : Set interval time of every shot

Total 0000:00:40 :This automatic data is generated by the system based on the quantity of photos and the interval time(for reference)

∨ :Next page -----

Fade in num 0P :Set up the quantity of fade in photos

Fade out num 0P :Set up the quantity of fade out photos

Preview frame 24FPS :Set up video frame rate (24p, 25p, 30p, 50p, 60p are available)

Preview 0,8 Sec :This automatic data (a duration of photos editing to a video) is generated by the system based on the quantity of photos and frame rate

Fade in num	0P ^
Fade out num	0P
Preview frame	24FPS
Preview	0,8 Sec ∨





↕ :Next page or previous page -----





 :Run frame REC

 :Run continuous shooting

 :Run stop-motion animation shooting

 :Run cycle frame REC

	Shoot move shoot ^
	Continuous ↵
	Stop-motion ↵
	Shoot move shoot ↵

- *  **Shoot move shoot** is lapse shooting with a pause between each photo. The camera doesn't move during exposure, which is applicable to long exposure shooting.
- *  **Continuous** is lapse shooting without pause between each photo. The camera is moving during exposure, which is applicable to shooting in good light conditions.
- *  **Stop-motion** refers to each picture motion being taken manually. Manually adjusting the position of the object.
- *  **Shoot move shoot** is shooting frame by frame, and it applies to product display.

Interface of Time-lapse shoot

going back : After starting the shooting mode, the system automatically moves the equipment back to the start point and the interface indicates the current running mode

X 0mm going back
P 0°
T 0°
Stop ■ Pause || i! 📷

Pause || : Suspend running and skip to the start-up icon

Stop ■ : Stop the current running and skip to interface of Exposure adjustment

Interface of Exposure adjustment

After pausing halfway through shooting, the interface shifts to the Exposure adjustment automatically. Users can change the current exposure time and shooting interval time

Exposure 0 sec
Hold time 0 sec
⊗ Quit Save ⊙

Interface of stop-motion animation

Shoot 📷 : Start up button of stop-motion animation (after pressing the button, the camera automatically moves to the next location and shoots)

X 0mm going back
P 0°
T 0°
QUIT ⊗ Shoot 📷 i! 📷

* While shooting, the user can pause or stop the time lapse. The interface of Frame REC shooting, continuous shooting, stop-motion animation, and Cycle Frame REC are similar to the above interface.

System Settings

The default slider distance is 1000mm. If the distance changes so do the settings. 25% of power consumption is applicable for horizontal operation or 3-4kg load in vertical, which can greatly improve the battery endurance. If the electronic motor section and Pan & Tilt Head are in OFF position, it is not possible to operate the Record, Time-lapse and Auto functions. Press the Version icon and check the firmware version of every axis. Once inconsistencies are found, please update all of them. Otherwise, this will cause undesirable effects.



Main interface of
System set up

```
Distance set 0.0mm
Slider power 25%
Language English
Version
```

Distance set :Set up the terminal point of the track rail (after the finishing setting, the slider does not run over the terminal point in any shooting mode)

Slider power :Set up power consumption of the slider(25%,50%,100% are the options)

Language :Select system language(Chinese, English, Japanese and German are the options)

Backlight :Set up the backlight time of the display screen (choose between 30 seconds, 1 minute and 5 minutes)

Sync Setting:Set up the frequency channel of the wireless motorised controller, or press and hold the left toggle to enter the Channel Setting interface

Pan rotation Forward: Adjust the operating direction of the pan axis. Forward direction is the default setting. If the opposite direction is preferred, please turn the equipment around

Tilt rotation Forward:Adjust the operating direction of the pitch axis. Forward direction is the default setting. If the opposite direction is preferred, please turn the equipment around

```
Backlight 30 sec
Sync Setting 0000 ←
Pan rotation Forward
Tilt rotation Forward
```





Slider :Open or close the recording and playback of the electronic motor section(ON is open, OFF is close)

Pan :Open or close the recording and playback of the pan axis(ON is open, OFF is close)

Tilt:Open or close the recording and playback of pitching axis(ON is open, OFF is close)

Zoom : Open or close the recording and playback of the focus axis(ON is open, OFF is close)

 **ON** : Open connection  **OFF** : Close connection

Slider		ON
Pan		ON
Tilt		OFF
Zoom		OFF

Host Ver 2.5 : Shows the current firmware version of wireless motorized controller



Head Ver 2.5 :Shows the current firmware version of the Pan & Tilt head

Slider Ver 2.5 :Shows the current firmware version of the electronic motor section

 : charging

 : low battery

 : high battery

Host	Ver 2.5	
Slider	Ver 2.5	
Head	Ver 2.5	

Interface of default set

Reset to defaults :Delete the customised settings and restore factory default settings while the recorded track is kept

Reset to defaults!!! ↗

Firmware update

1. The firmware of iFootage Motion Control series will be regularly updated.
2. While connected to the internet, users can update the firmware of each section only on Windows 7/Windows 8 or 8.1 computers.
3. Please come to www.footagegear.com/support.php and download the latest firmware which is released irregularly.
4. Before unzipping the firmware archive, please make sure your antivirus is disabled.
5. Connect the Mini USB port to the computer's USB port, then select the relevant firmware to update. The slider is for the electronic motor section, the host is for the wireless motorised controller, and the head is for the Pan & Tilt Head.
6. Double click on the file to run, select ----- until it displays Complete, which means the update has finished.
7. Start all sections after finishing the update, and check section version of the wireless motorised controller: SET----Check version; if, in this interface, the current version is shown as the latest one, it means the firmware has updated successfully.

Certificate of conformity

The manufacturer declares that the iFootage Wireless Motion Control System Series S1A1/MOTION X2/S1A3 is in compliance with the essential requirements of CE certificate and other related regulations.



After-sale service

1. Warranty terms

- 1) iFootage provides limited support on the electrical parts if the function failure is caused by the product quality under normal use.
- 2) The warranty period is 1 year from the date of purchase.
- 3) During warranty, iFootage offer free replacement or repair services within the warranty scope.

2. Situations that are not included in the warranty terms

- 1) Users disregard the iFootage product manual guidance when installing or operating the equipment.
- 2) Function failure caused by abrasion, abuse, improper operation or chemical reagents.
- 3) Function failure caused by installing non-iFootage parts on the product
- 4) Function failure caused by conversion.
- 5) Function failure of electronic devices caused by infiltration of liquid.
- 6) Function failure caused by electronic interference.

After-sale service

- 7) Function failure of iFootage electronic products caused by using a poor quality battery or connecting to a non-conformity power supply.
- 8) Function failure caused by accident or human factors, such as transportation, collision, operational errors or non-conformity input voltage, and so on.
- 9) Function failure caused by force majeure (including but not limited to fire, earthquake, thunder strike, etc).
- 10) The damage or loss of parts during transport (please consult the related logistic company).

3. Paid service (users can choose paid-service when function failure occurs beyond the warranty scope)

- 1) The cost of paid service only includes material and shipping fees for products within 1 year from the date of purchase.
- 2) The cost of paid service includes testing, material, repair, and shipping fee for products that have passed the warranty year.

4. Service procedure

- 1) When function failure occurs, please contact the retailer who sold the product to you to confirm the failure situation, service range and solutions in the first instance. Before this step, please provide:
 - a) Certification of purchase.
 - b) The details of function failure, such as surroundings (weather, etc.), operation, the product's performance and any other relevant details.
 - c) Your contact details.
- 2) iFootage or the retailer will confirm the service range according to the after-sale service terms.
- 3) After receiving the defective product and checking the product damage (if any), iFootage or the retailer will contact the customer to confirm the repair fee. Only once the customer confirms that they accept the repair fee, will the Crepair the product. In the case of severely damaged (beyond repair) products, if still within the warranty scope, iFootage or the retailer can replace it with a new one; if beyond the warranty period, customer must contact service support.

5. Shipping fee

If within the warranty period, customers only need to pay for shipping of returned products; if beyond warranty period, customers need to bear double fees.



IFootage INTERNATIONAL (HK) LIMITED

Origin:Guangdong, China

Website:www.footagegear.com